

USER'S MANUEL
MODEL PK 35
PROFILE BENDING MACHINE



PK 35

İZMİR YOLU 22.KM MÜMIN GENÇOĞLU CAD. 16285 BURSA / TÜRKİYE

Tel : +90 224 470 01 58 (PBX) Fax : +90 224 470 07 70

web : www.sahinlermetal.com e-mail : info@sahinlermetal.com

EC DECLARATION OF CONFORMITY

MANUFACTURER

NAME : ŞAHİNLER METAL MAKİNA ENDÜSTRİ A.Ş
ADDRESS : İzmir Yolu 22. Km Mümin Gençoğlu Caddesi 16285 Bursa – TÜRKİYE
TEL : +90 224 470 01 58 **FAKS** : +90 470 07 70 **WEB**: www.sahinlermetal.com

Name and Address of the

Person authorized to compile the

technical file : FERHAN ŞAHİN

İzmir Yolu 22. Km Mümin Gençoğlu Caddesi 16285
Bursa – TÜRKİYE

The undersigned declares that the described products meet the essential requirements of the below mentioned standards as based on Machinery Directive **2006/42/EU**, Low Voltage Directive **2014/35/EU**, Electromagnetic Compatibility Directive **2014/30/EU**

The item of equipments which identified below has been subject to internal manufacturing checks with monitoring of the final assessment by **ŞAHİNLER METAL MAKİNA ENDÜSTRİ A.Ş**

MACHINE DESCRIPTION : Profile and Pipe Bending Machine

MODEL : PK-35

APPLICABLE DIRECTIVES :

2006/42/EU MACHINE SAFETY DIRECTIVE

2014/35/EU LOW VOLTAGE DIRECTIVE

2014/30/EU ELECTROMAGNETIC COMPATIBILITY DIRECTIVE

APPLICABLE REGULATIONS :

EN ISO 12100:2010; EN ISO 13855:2010; EN 60204-1:2006/A1:2009; EN 61000-6-2:2005; EN 61000-6-4:2007/A1:2011; EN ISO 11202:2010; EN 614-1:2006+A1:2009; EN 953:1997+A1:2009;

SIGNED ON BE HALF OF THE MANUFACTURER

NAME : FERHAN ŞAHİN

POSITION : General Manager

PLACE/ DATE : BURSA /

SIGNATURE :

LABELS



DANGER OF ELECTRIC



EMERGENCY STOP



GROUNDING SYSTEM



WORKING VOLTAGE

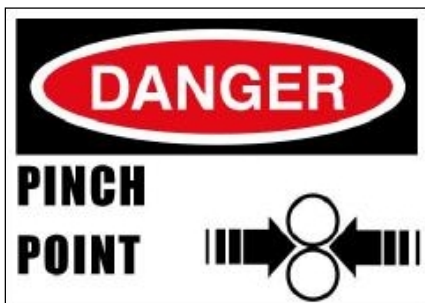

DANGER



DANGER

INDEX	Page Nr.
GENERAL NOTES	1
GENERAL WARRANTY TERMS	3
GENERAL SAFETY TERMS.....	4
TRANSPORTING, LIFTING AND CARRYING.....	5
TECHNICAL PROPERTIES	6
CAPACITY CHART	7
STANDARD ROLLER DIMENSIONS.....	8
CHANGING THE ROLLS	9
FOUNDATION AND MAIN DIMENSIONS OF THE MACHINE	10
OPERATING PK 35 AS HORIZONTAL.....	12
START-UP INSTRUCTIONS.....	13
OPERATION	15
MAINTENANCE	18
LUBRICATION	19
PART LIST	20
SPECIAL ACCESSORIES FOR MODEL PK 35	21
ELECTRIC.....	22

GENERAL NOTES

1. Introduction

This User's Manual is absolutely for your safety and is essential for the machine to have a long production life. As long as you keep up with our Manual you will be able to run your machine smoothly and safely. Keep in mind that the machine is designed absolutely to perform maximum safety and for efficient working.

In this Manual you can find instructions and information about:

- *Correct installations of the machine*
- *Description of the functional parts of the machine*
- *Set-up and start-up adjustments*
- *Correct standard and scheduled maintenance*
- *Simple safety regulations and accident prevention.*

Therefore, as far as the user's safety is concerned, in this handbook the possible risks connected with machine operation are pointed out as follows:



ATTENTION: *Showing the risks of accident, if instructions are not followed.*



WARNING: *Showing the probable damages to the machine or equipment, if the instructions are not strictly followed.*



NOTE: *It gives useful information.*

It is certainly necessary that the operator should read and understand all the ATTENTION, WARNING notes specified in this Manual before starting with operation of the machine and before any lubrication or maintenance intervention.

On all steps of installation, operation and maintenance safety must be your first concern for the protection of yourself, other users and the service of the machine.

In case of any failure please first refer to this Manual, and then if a solution cannot be found contact first of all the distributor where you purchased our product. Do not forget to refer to the drawings and the numbers for any spare part needed or to define any problem. Make sure you have the serial number and production year of the machine. Our technical staff will make their best to help you in the most convenient way.

2. Transport

*Remove any protective crates around the machine and read the instructions on related chapters of this Manual carefully to set up the machine. If the machine is damaged while transport, **immediately take some photographs for insurance claims.***

Take precautions while loading / unloading or moving the machine to avoid any injuries. Refer also to related chapter of this Manual for the best way of handling the machine.

3. Electrical Information

All necessary connection procedure can be found on this Manual. Do not try to connect the machine before reading these procedures and fully understanding the drawings. Have the machine connected by a qualified electric technician. For, as we made clear in the “general conditions of guarantee”, under no circumstances installing mistakes, one of which is the electrical connection mistake, can be covered in the guarantee agreement. Always turn off power before making any connections or disconnecting the machine.

4. Maintenance

Your machine is designed and produced to work efficiently and smoothly. To achieve this you should also take care while operating the machine. Regard Maintenance sections to have the longest life from your machine. Try and use original spare parts where necessary and most importantly do not overload the machine or do not make any unauthorized modifications.

5. Safety

Take all precautions possible to avoid any personal injury while using the machine.

Keep in mind to protect the third party people around the machine. Refer to safety

instructions.

GENERAL WARRANTY TERMS

- *Your machine is covered by manufacturer's guarantee for a period of **12 months** from the date of purchase against manufacture defects. The warranty period does not exceed 18 months from the date of delivery from the manufacturer's factory.*
- *Warranty covers only manufacture defective parts and / or components that are reported as "defective" by a Sahinler Technician or the Agent Technician and must be reported to Sahinler in writing by fax or email.*
- *The manufacturer is responsible for the supply of free of charge spares only and cannot be held responsible for loss of work.*
- *Shipping and customs fees for the spare part must be paid by the end-user.*
- *If a technician travel is necessary Sahinler will not charge for labor and workmanship costs but the customer must pay traveling and accommodation charges.*
- *A Warranty claim does not relieve the Customer from payment obligations.*
- *The Customer can not ask or demand any reimbursement of damage nor the Customer will have the right to extend or delay payment obligations nor the cancellation of order and the refunding of damages as the guarantee is given for the defective parts of the machine and not for the job.*



Note: All warranty claims must be applied with the Model, Serial Number and the Manufacture Year of the machine.

GENERAL SAFETY TERMS

1. Machine's Safety Accessories and Accident Prevention Terms

- *The machine is provided with fixed shelters for the protection of all gears. But some mobile parts, because of their shape for the bending processing cannot be protected within a case. However, safety is guaranteed by the machine features and by the use of "human presence" controls.*
- *The machine is controlled by means of main switch and speed selection knob. During operation the specified safety distance must always be observed.*
- *No other persons except for the qualified and well-trained operator should be allowed to use the machine and to be present in the working area of the machine.*
- *Any damaged or defective connections to the different energy supplies must be replaced.*
- *All interventions concerning installation, start-up, change of equipment, use, change to the use and the operation, regular maintenance, inspection and periodical maintenance can be performed only after disabling the machine according to relevant chapter of this handbook.*
- *For any intervention to change the machine's use, please contact to ŞAHİNLER METAL MAKİNE ENDÜSTRİ AŞ. previously and ask for their written approval.*

2. Abnormal Conditions

In order to avoid unusual working conditions, in the following several recommendations to the operator are listed. Also, do not forget that this machine can be used only in the conditions presented in this operation and maintenance handbook.

- *Before connecting the machine double-check electrical connections read the instructions carefully. For, almost 65% of the failure reports we receive are based on either wrong electric connection or use in contradiction to the User's Manual.*
- *Avoid the approach of persons to the operator while the machine is running.*
- *Loading and unloading of the material should be done according to the instructions of this handbook.*
- *During the bending process avoid holding material with the hand.*
- *Never wear garments with loose parts, which may be dragged by the machine parts, long loose hair, necklaces, rings etc.*
- *Never use goods except for the allowed ones as operational materials.*
- *Never run the machine without safety devices.*
- *Don't climb on the machine.*
- *If the customer wants to install on the PK 30 machine a piece of equipment, which has not been supplied by ŞAHİNLER METAL MAKİNE ENDÜSTRİ AŞ. the compliance with the safety conditions explained here has to be checked.*
- *The machine cannot be installed and used in corrosive environments.*
- *The machine must always be operated with one qualified operator who has the required knowledge to use this machine properly.*

TRANSPORTING, LIFTING AND CARRYING

Before preparing the machine for installation and start-up, an accurate visual control is required in order to detect any possible damages occurred during transporting and handling phases.

Your machine is located on a wooden grid and the package is a waterproof plastic cover.

If one or several parts of the machine have been damaged while shipping, the installation of the machine has to be suspended. ŞAHİNLER METAL MAKİNE ENDÜSTRİ AŞ. has to be informed of the unexpected occurrence straight away.

While lifting take care of these points:

- Always lift and carry the machine from the handles.
- Use a steel rope capable of carrying 500 kg.
- Do not forget the Mobil Control Panel.
- Take precautions for handling and lifting.
- Check if the load is properly balanced by lifting it some centimeters.
- Lift the machine, proceeding with care, without sudden accelerations or quick changes of directions.
- Place the machine where it must be installed, lower the machine slowly till it touches the floor.

Figure 1 shows a way of carrying the machine. You can use a crane with hook or a forklift for handling operation.



Figure 1



Attention: Lifting and carrying operations should be carried out by skilled workers, such as truck operator, crane operator, etc. Also, it is necessary to keep in mind that having large safety margins will provide you efficient working conditions and enable you to take into consideration most of the precautions.

TECHNICAL PROPERTIES

As a superior model in its own class the PK 35 is equipped with a powerful motor and a low noise reduction gearbox, which gives the machine power to bend with ease. The digital Read-Out (optional) that can be fitted to top roll gives higher accuracy and helps increase the efficiency. By using Mobile Control Panel. PK-35 F includes foot pedal and an emergency stop you can easily and safely bend the required materials. General Technical Information of PK 35 is given below.



MODEL: PK 35		
Shaft Diameters	Ø mm	50
Roll Diameters	Ø mm	155
Working Speed	m/min	4,5
Motor Power	kW	1,5
Weight	kg.	400
Length	mm	1100
Width	mm	750
Height	mm	1400

STANDART SPECIFICATIONS

- Steel Frame
- Two rollers are powered
- Rolls are hardened
- Rolls Shafts are Special Steel material hardened and grinded
- Standard Rolls
- Foot pedal control
- Guide Rolls
- Horizontal and Vertical Working Position
- User's manual book

SPECIAL FEATURES

- Pipe / Tube Bending Rolls
- Profile Bending Rolls
- Angle Bending Rolls
- Digital Read-Out
- Special Lateral Angle Guides















SAFETY UNITS

- Emergency Button on Mobile Control Panel
- Various DANGER signs around the machine
- Brake motor (Optional)
- Overload Circuit – Breaker



Note: Due to various safety regulations, the specifications presented here can change from country to country without prior notice. Above dimensions and other characteristics can also change without prior notice due to our constant improvements on our products.

CAPACITY CHART

no	profile type	Maximum size	min. int Ø	notes
1		40 x 10 60 x 10	400 500	Standard rolls
2		60 x 10 100 x 15	350 450	Standard rolls
3		20 35	300 900	Standard rolls
4		Ø30 Ø35	400 600	Optional rolls
5		Ø30 x 2 Ø70 x 2	500 1000	Optional rolls
6		Ø33.7 x 2.3 (1") Ø60.3 x 2.9 (2")	350 1000	Optional rolls
7		50 x 40 x 3 70 x 30 x 2	1200 1200	Optional rolls
8		40 x 40 x 3 50 x 50 x 3	600 1700	Optional rolls
9		40 x 40 x 5 50 x 50 x 5	600 800	Optional rolls
10		30 x 30 x 3 50 x 50 x 6	500 1000	Optional rolls
11		50 x 50 x 6 60 x 60 x 7	500 700	Standard rolls
12		50 x 50 x 6 60 x 60 x 7	500 700	Standard rolls
13		UPN 60 UPN 80	700 1000	Standard rolls*
14		UPN 30 UPN 80	800 1200	Standard rolls*

- ♦ Capacities are given for 24 kg/mm² plate yielding strenght.
- ♦ We reserve the right to make changes without notices.

* Special washer (spacer) can be necessary



Warning: Do not feed profiles having a higher thickness than specified for the capacity of the machine.

Do not feed more than one piece at a time.

Do not use the machine for any other scope the one for which it has been designed.

STANDARD ROLLER DIMENSIONS

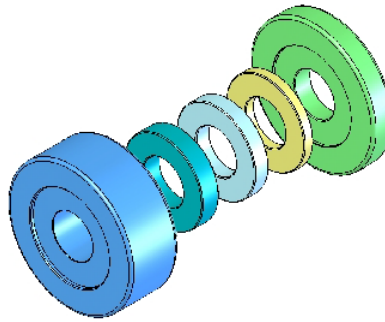
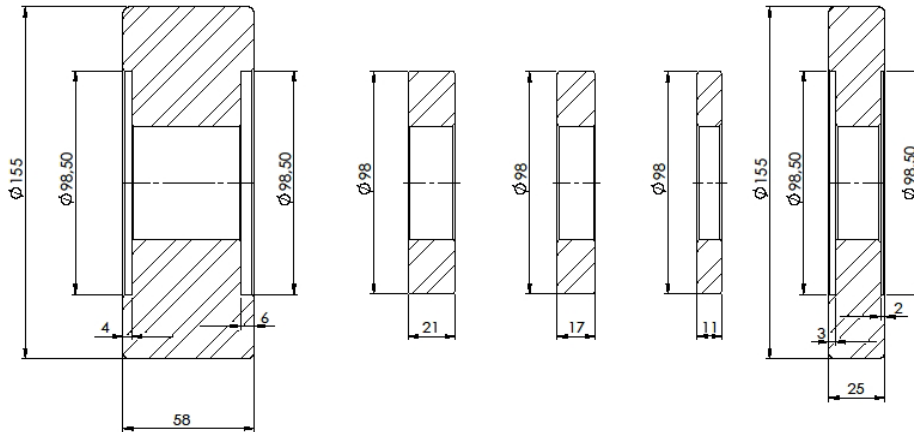

Note: As the three rollers have the same and standard sizes, the dimensions given in figure 1 is valid for them all.

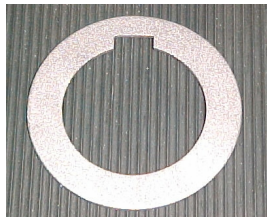

Figure 2



Figure 3

We supply 6 pieces of spacers with the machine (as shown in Figure 2). These spacers can be used to obtain different width with the standard set of rolls. The spacers are divided into two groups as shown below.

This table is standard sequins of dimensions.

dimension	unit	group 1
diameter	mm	98
width	mm	28
piece		3

CHANGING THE ROLLS



Figure 1

In order to change the lower rolls:

- Stop the machine if it is active
- Dismantle the nuts at the end of the lower rolls' shafts
- Pull out the rolls
- Replace with the ones you want to use
- Tighten the nuts again.

To change the upper roll:

- Stop the machine if it is active
- To pull the top roll out as shown on the picture please take with an appropriate 10's allen key out by hardening.
- Replace with the ones you want to use
- Then please harden it with the same operation.

FOUNDATION AND MAIN DIMENSIONS OF THE MACHINE

Figure 1 shows the main dimensions of the machine.



Note: For a correct operation the machine must be placed on a flat, preferably concrete base and even floor.



Note: Figure 2 shows the area into which anyone except for the operator is forbidden to enter. that this area is illustrated considering the machine located horizontally. If you operate it vertically, then the borders will be the same. That is, no matter how you located the machine (vertical or horizontal) you should always keep the safety distance of one meter around the machine.



Note: The manufacturer doesn't accept any responsibility for damages due to the non-observance of the above specifications.

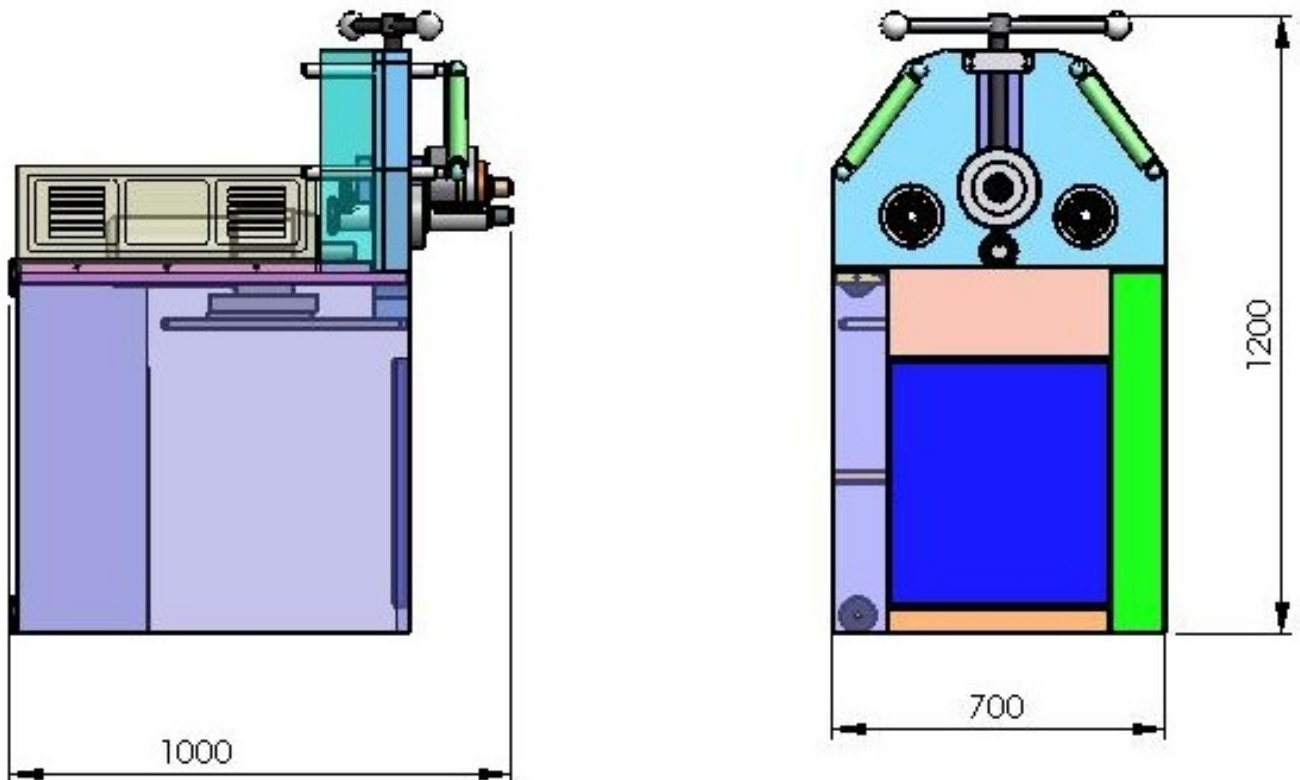
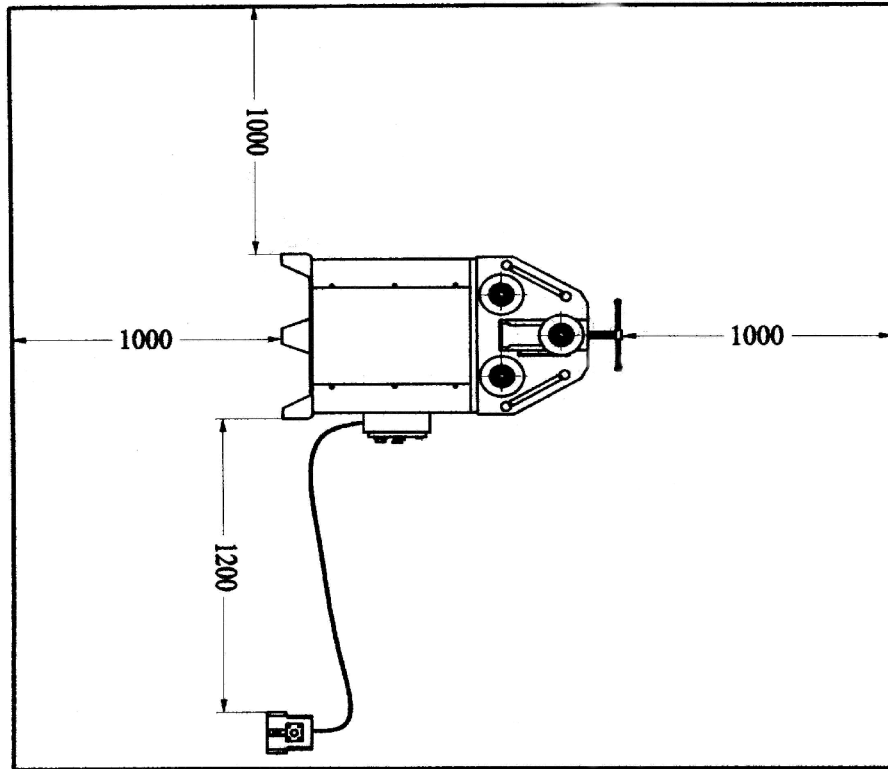

Figure 1



Safety Area (Figure 2)



OPERATING PK 35 AS HORIZONTAL

Before positioning the machine it is necessary to leave enough working area for the proper bending operations such as: extraction of the cylindrical profile, feeding of the semi product, bending of big diameters.

If you have no alternative to install the machine in a broad area but a low-height area, then there is a solution to this problem as shown in figure 2.

To set the machine horizontally follow these steps:

Wrap a belt capable of carrying at least 500 kg around the top roll's shaft (shown by ① in fig.1).

- Lift the machine slowly by means of a forklift or a crane with hook.
- When you are satisfied that you have lifted the machine to the degree that only the corner shown by ② in figure 2 touches to the floor, rotate the machine right slowly with the help of a person so that the mass center of the machine tend to be at the right side of that corner.
- After that, slowly lower the machine.



Figure 1



Attention:

Do not wrap the belt around the top roll adjustment screw so that it may be bent or its teeth may be damaged.

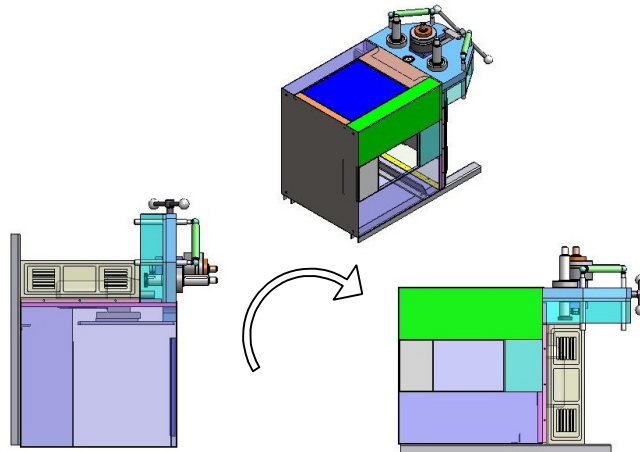

Figure 2

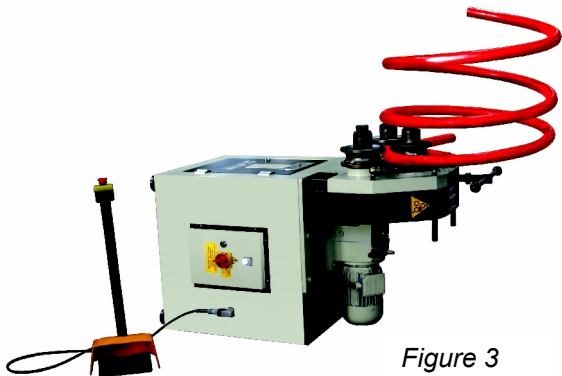

Figure 3

Figure 3 shows an example of horizontal working.

START-UP INSTRUCTIONS

1. Materials and Products

The machine is mainly steel and it is not designed for handling inflammable or detrimental products. It is duty of the customer to check if the processed materials respond to these requirements. Also, it is duty of the customer to check if the processed materials can be dangerous for the operator working nearby.

When selecting the most appropriate operation material you should keep in mind those instructions:

- Material must be clean out of oil and dry.
- Hardness value must always be same thorough the material.
So, we recommend you to buy certificated steel.
- Parts to be bended should have smooth surface to fulfill the procession correctly and easily.



Note: The thorough cleaning of the rolls is absolutely necessary in order to avoid possible sliding of the profile due to grease residues on the rolls.

2. Electrical Connection

Have a qualified electrician connect the machine to the electric supply. In some cases inverse electrical connection causes the motor burn out. To avoid such an undesirable event, after having connect the machine see that the motor turns to the direction shown by arrow when activated. Or you can check to see if the rolls are rotating to the same direction of the pedals. That is, if the right pedal is pushed, the rolls should rotate right and if the left pedal is pushed, the rolls should rotate left. If the machine does not comply then inverse the electric cables.

3. Electric Box

1. Electric box lock
2. Main Switch
3. Electric On Indicator
4. Start Button
5. Stop Button
6. Infinitively Variable Speed Selector

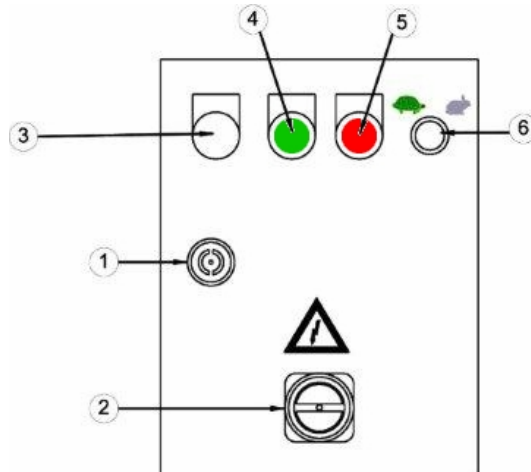

Attention: Electric box cover should stay closed during the machine power on.



Warning: It is suggested to protect the main electric line from possible overloads by means of safety switches.

4. Foot Pedal

The foot pedal is equipped with an “emergency button” which instantly stops all the machine activity by disabling the electric supply until released.

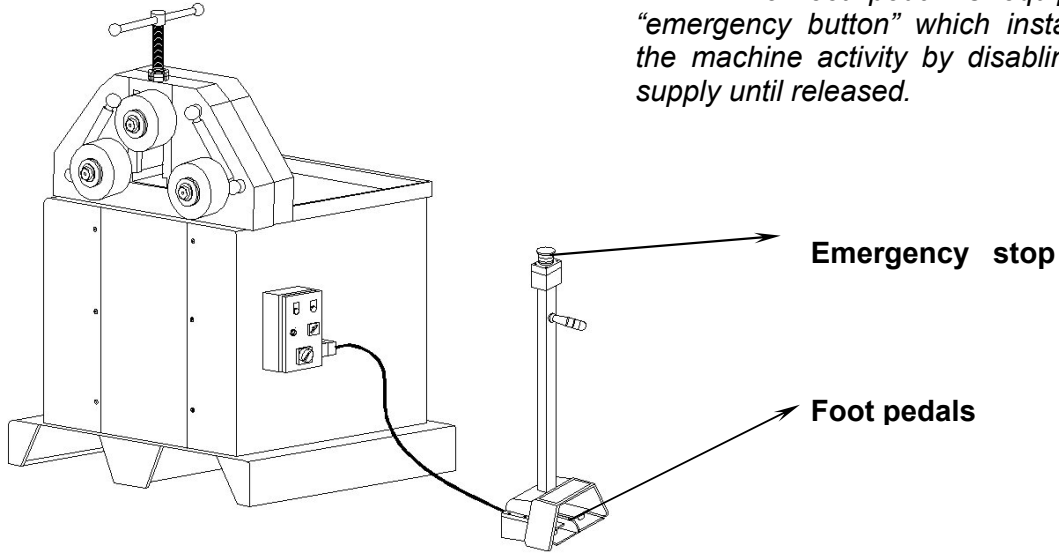

5. Starting The Machine

Following steps will help you start the machine and get ready for the first bending operation. See the sections identifying the necessary switches and buttons.

- Make sure the electrical connection is correct
- Turn on the “main switch”
- You will see electric on “indicator”
- Push “start button”
- Choose a speed from the “speed selector”
- Use the “foot pedals” to rotate the rolls
- Make bending
- Use the “emergency button” on “foot pedal” to stop the machine
- Turn off the “main switch”

6. Basic Operation Terms

The PK 35-F has two rolls powered and top roll idle. The lower rolls are direct driven by a reducer motor. Top roll can be adjusted by a screw driven system to make the bending in a wide radius range. Therefore, bending operation is simple and smooth however requires experience for efficient working. Following recommendations will be helpful during operation:

- It is recommended that the user have basic bending information with this kind of machines.
- Making a tight bend in one pass is not possible. So you need several passes before you can achieve a certain radius. Tighter curves and full radii always take a lot of time.
- During operation never wear garments with loose parts, which may be dragged by the machine parts, long loose hair, necklaces, rings etc.
- Use emergency button in case of any emergency.

OPERATION

1. Operating Instructions

Place the material on the rolls flatly as shown in the figure 1. Make sure that material is placed parallel to the ground and touching all three rolls at the same time. This position is called "zero position".

Move the upper roll down like in figure 2 and position it to apply enough force to bend the material. Do not apply force more than necessary. If you apply too much force with the help of moving the upper roll down a lot more than enough, you may deflate the material during bending operation.

Push the foot pedal to rotate the rolls to which direction you want (look at figure 3). To get desired diameter value make more than one pass by gradually lowering the upper roll after each pass. After a pass if the diameter value is bigger than expected, move the upper roll down to apply more force. If the case is vice versa, than move the upper roll to upside by making use of milimetric ruler.

It is likely that the material will intend to bend right or left because of the existence of bending forces. To prevent this, you must adjust the guide rolls as shown in the figures 4 and 5.

As the guides are adjustable on top and bottom, you can arrange them to the opposite side of the material's directional inclination.



Note: To get a circular profile, side guide joints must be parallel to the machine surface. Otherwise, you just get spiral profiles.

Figure 6 shows bending operations for different kind of sections with special rolls.

In case of bending long materials, material feeder is advised to use in order to keep workpiece parallel to the base ground (see figure 7). This will make easier to bend such workpieces.

Upper rolls

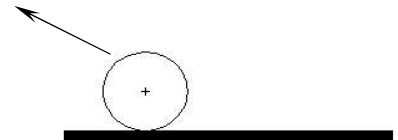

Figure 1

Lower rolls

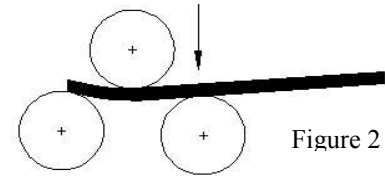

Figure 2

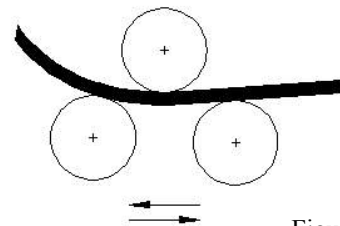

Figure 3



Figure 4



Figure 5



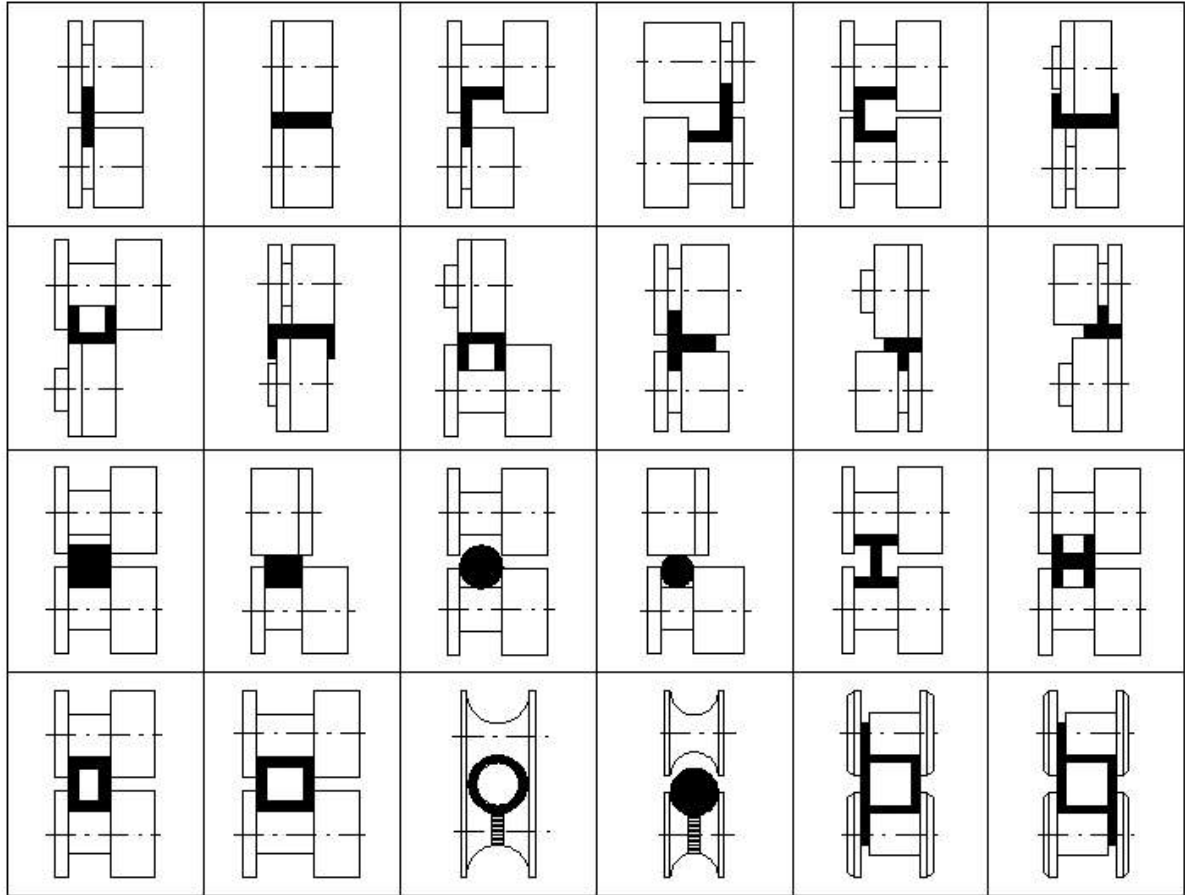

Figure 6

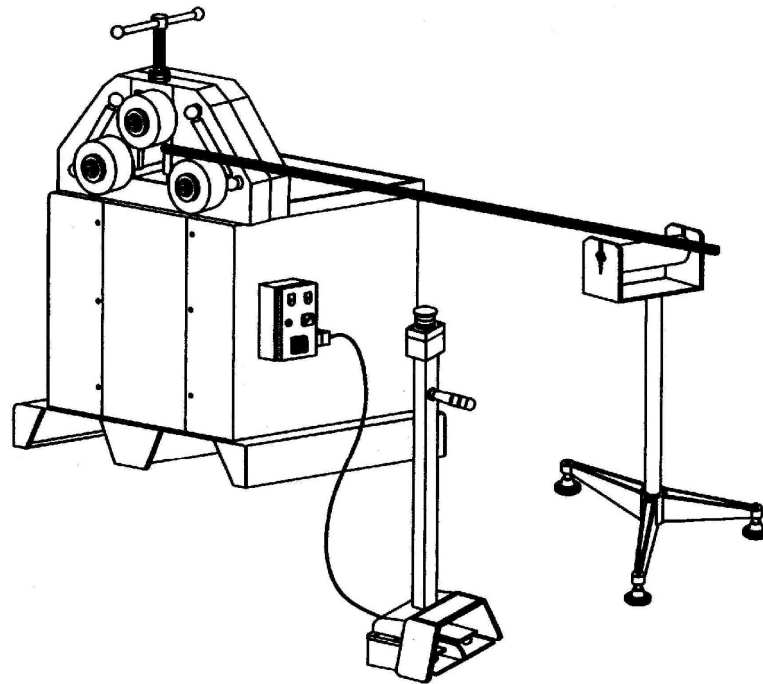

Figure 7



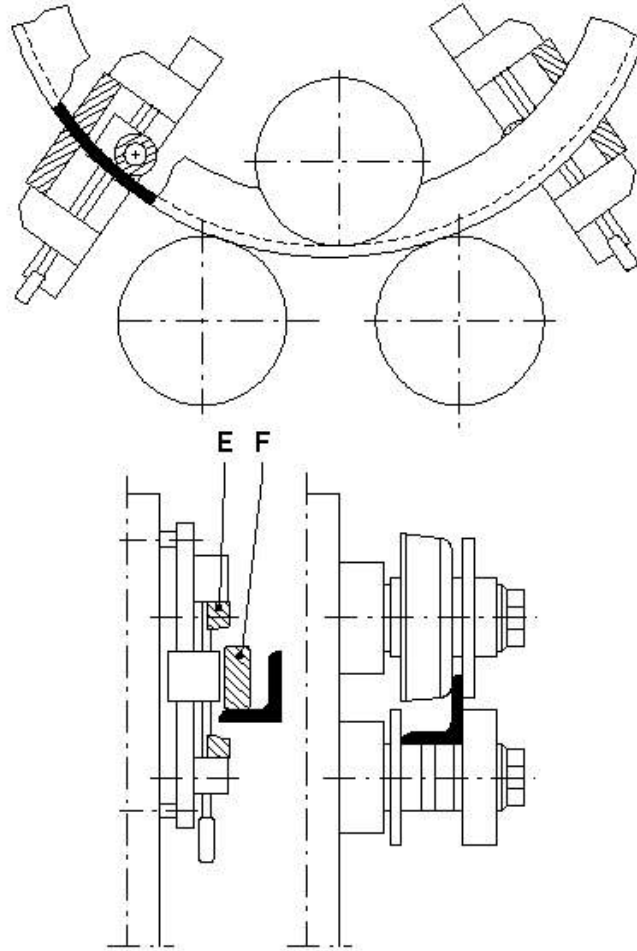

Figure 8

Figure 8 shows the use of “Leg-In Bending Guide Rolls”. These guide rolls are special accessory for bending leg-in (angle) material and are available for extra cost. They are adjustable for any size of material and easy to use. Special rolls are recommended for any batch jobs of leg-in or leg-out material. Some of the angle materials can be bent with standard rolls

2. Operational Hints

- Always clean the rolls and the material of dust, dirt and grease for bending
- If you are bending a pipe do not rotate the pipe while bending
- We advise you to fill the profiles or pipes with sand or any similar material if they have a wall thickness of less than 2 mm
- Do not overload the machine and use special rolls for profiles as well as pipes
- Operate safely keeping in mind the third party people around the machine
- Leave enough workspace around the machine
- The machine can also work horizontally for extremely large diameters
- The machine has double-speed motor.

MAINTENANCE

A suitable maintenance is also compulsory to get a maximum machine life and optimal working conditions for machine's efficiency.

A regular maintenance interventions should be performed by a well-trained safety responsible and if possible by a mechanical engineer.



Attention: Regular and scheduled maintenance interventions cannot be performed by running machine. The main switch must be turned off. Besides, a warning signal telling, **“DO NOT ACTIVATE - MACHINE IN MAINTENANCE”** must be clearly visible on the machine.



Attention: Any processing system, which may endanger the machine safety, must be avoided.

As the machine does not include any kind of hydraulic system, it is simple to lubricate its functional parts as shown in the below.

- Firstly, turn off the machine if it is active by moving the **main switch** “0” on the electric box.
- Remove the back lid by dismantling its screws.
- Grease the power joints inside the machine with the help of an oilfeeder (*).
- Also grease the upper roll adjustment shaft (shown by X points in figure 1)(**).
- Lubricate the reduction gearbox with OIL SAE 30 (illustrated by point Yin figure 1).
- After the lubrication, assemble again the back lid and the protections.
- Restart the machine according to the start procedure, and check if there are any anomalies due to faults or unintentional tampering during maintenance.



Attention: For replacement of oil, use a funnel with a filter in order to avoid that impurities enter into the gearbox or among the other movable parts and damage the good functioning of the machine.

Internal cleaning of the electric box is also needed and must be done like in the following:

- Turn off the machine moving the main switch on the electric box “0”.
- Disconnect the mains supply from the electric board.
- Open the electric box lock.
- Do not use liquid detergents while cleaning the electric box inside.
- Check the connections to the terminals of the different devices.
- Tighten any loose connections.
- Close the door of the electric box and check if it is closed perfectly enough.
- Connect the electric board to the mains.
- Restart the machine according to the start procedure, and check if there are any anomalies because of faults or unintentional tampering during maintenance.

(*): Use commercial grease for lubrication and make this operation once per month.

(**): Use “MOBIL VACTRA OIL No: 2” or equivalent and lubricate this shaft once per week.

LUBRICATION

General Maintenance

The machine needs to be lubricating periodically for efficient working and longer to be lubricated periodically for efficient working and a longer life. You can see the points of lubrication list below and a lubrication chart for periods of lubricated

Lubricate chart

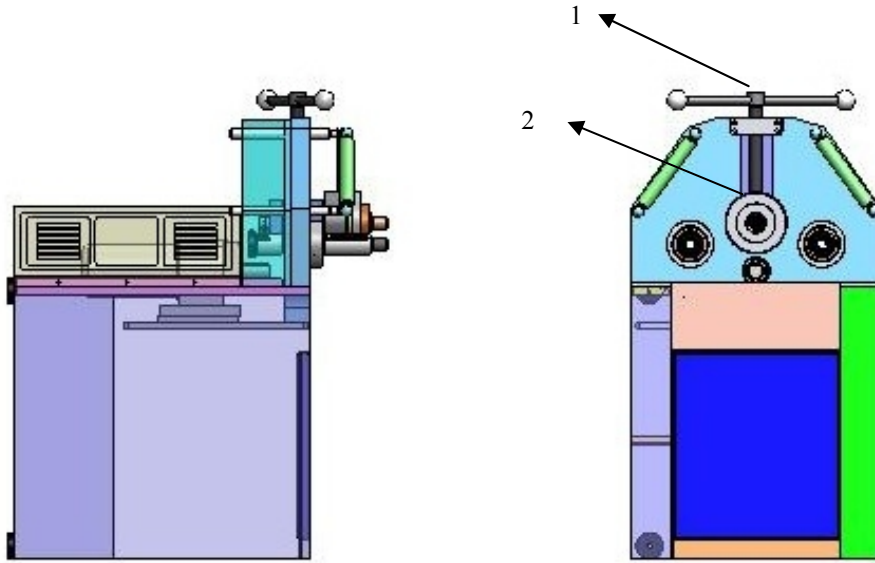

IMPORTANT

The rolls of the machine must **NEVER** be greased or lubricated. Because then the rolls will slip the material and will not bend. Always keep the rolls clean and free from grease or any lubricant. Also make sure that the material is free from grease and dirt.

These points must be greased periodically at least once a month or more if daily usage exceeds 8 hours a day. Note that some of these points are actually inside the machine cover and the front cover must be removed in order to reach them. Any standard commercial grease can be used for lubrication.

Num ber	Part no	period	what to do
1	Top roll Adjustment	Every Week	Grease
2	Top Roll Housing	Once a month	Grease

PART LIST

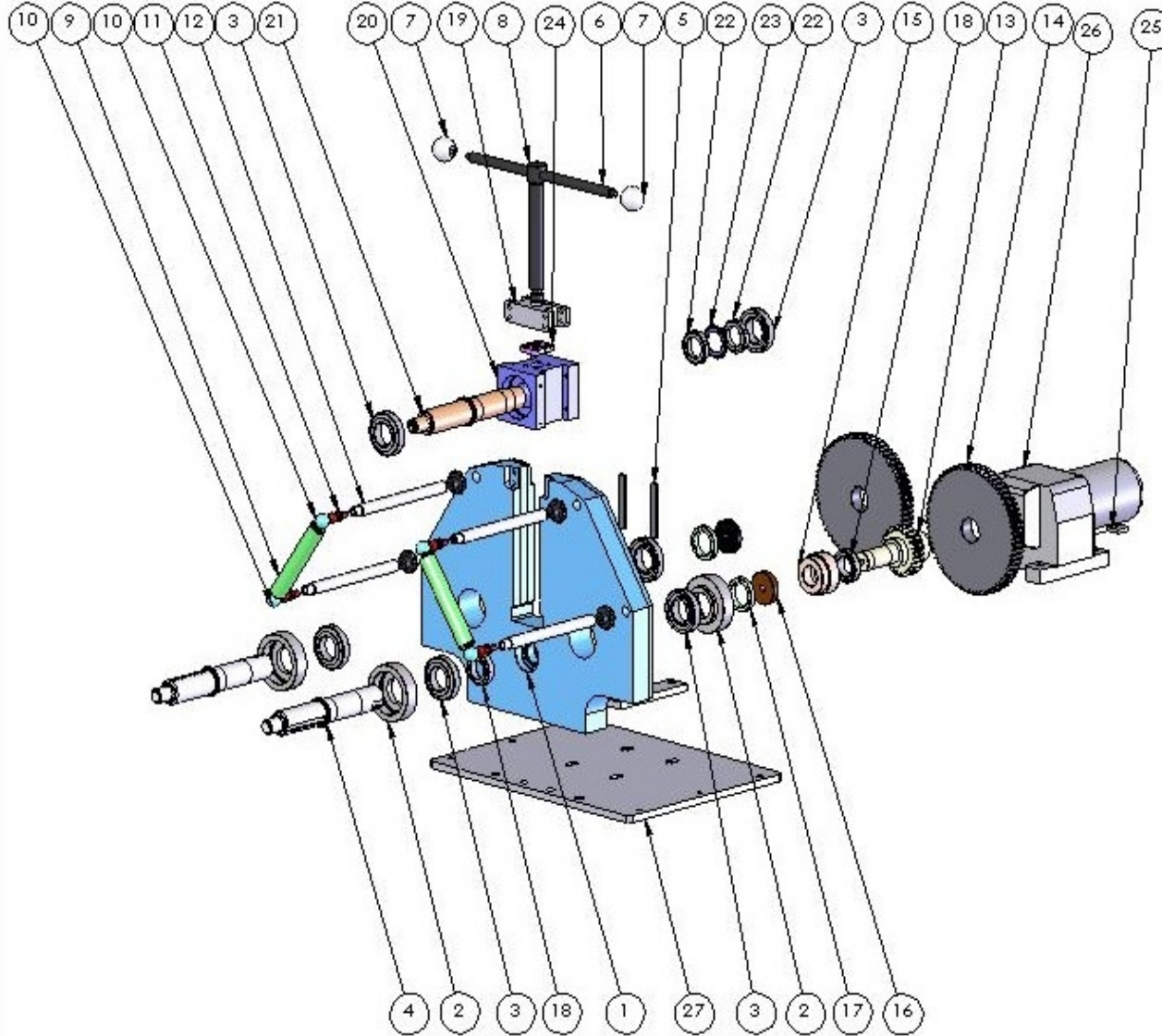

NO	PCS	PART NAME
1	1	STEEL FRAME
2	4	FLANGE
3	6	BEARING
4	2	BOTTOM SHAFT
5	2	KEY
6	1	TOP ROLL ADJUTMENT HAND LEVER
7	2	KNOB
8	1	TOP ROLL ADJUSTMNET
9	2	GUIDE ROLL JOINT
10	4	GUIDE ROLL JOINT
11	4	GUIDE ROLL JOINT ADJUSTMENT SCREW
12	4	LATERAL SIDE SCREW
13	1	HANDLE
14	2	GEAR
15	1	GEAR
16	2	BUSHING
17	2	SPACER
18	2	BEARING
19	1	BEARING CHOCK
20	1	TOP SHAFT BLOCK
21	1	TOP SHAFT
22	2	SAFETY NUT
23	1	MB
24	1	UPPER PLATE
25	1	MOTORS
26	1	REDUCER
27	1	BOTTOM PLATE
28	2	FRAME BOTTOM PLATE

"

||

SPECIAL ACCESSORIES FOR MODEL PK 35



Various special rolls;

For bending

1. *Aluminum profiles*
2. *Pipes, tubes*
3. *Hollow sections*
4. *Angle sections*

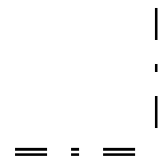

sahinler

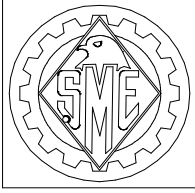

ŞAHINLER METAL MAKINA ENDÜSTRİ A. S.

Izmir Yolu 22. km. Mümin Gencoğlu Caddesi
 16285 BURSA/TÜRKİYE
 Tel. (+90 224)470 01 58 (PBX - 6 Hat/Line)
 Fax.: (+90 224)470 07 70 - 470 09 05
 www.sahinlermetal.com email: info@sahinlermetal.com

Customer :
 Project name : PK-35 PROFILE BENDING MACHINE - 220V
 Drawing number : 06072012
 Customer's address:

Manufacturer SAHINLER METAL MAKINA ENDUSTRI A. S.

File name (\EPLAN4\P): PK3525
 Drawn by : ASIM CANBAZ
 Checked by : FIRAT CILINGIR
 Responsible for project : FIRAT CILINGIR

Start Date : 06. Jul. 2012 The Last Page : 6
 Complete Date : 06. Jul. 2012 Total page : 6

Date	26. May. 2014	PK-35 SINGLE PHASE (220V)
Drawn by	ASIM CANBAZ	
Checked by	FIRAT CILINGIR	
Norm	Original	

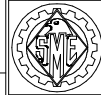

sahinler
 METAL MAKINA
 ENDUSTRI A. S.

COVER PAGE

Drawing number: 06072012

File number:
PK3525Project name:
PK3525

P. 1

6 P.

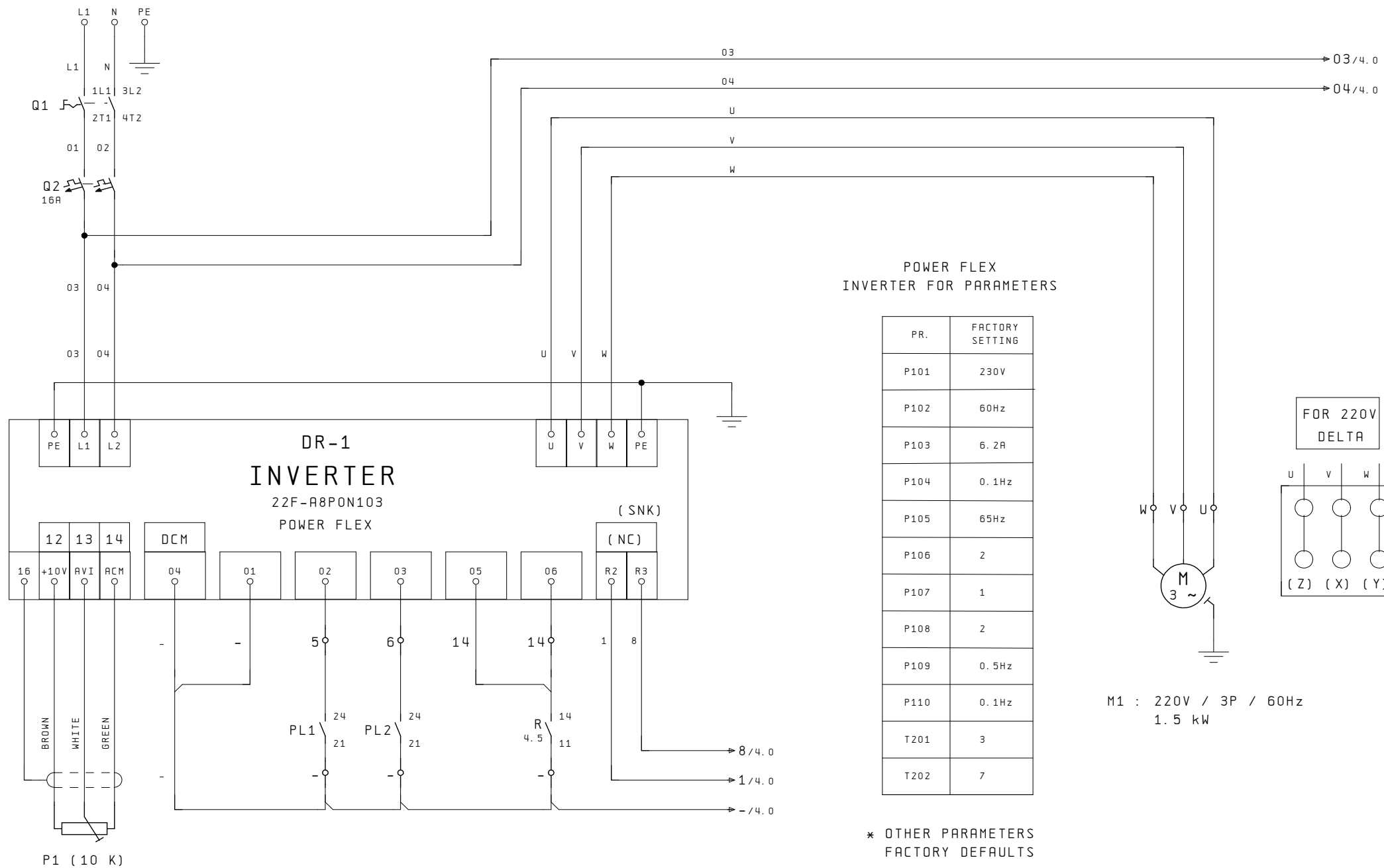

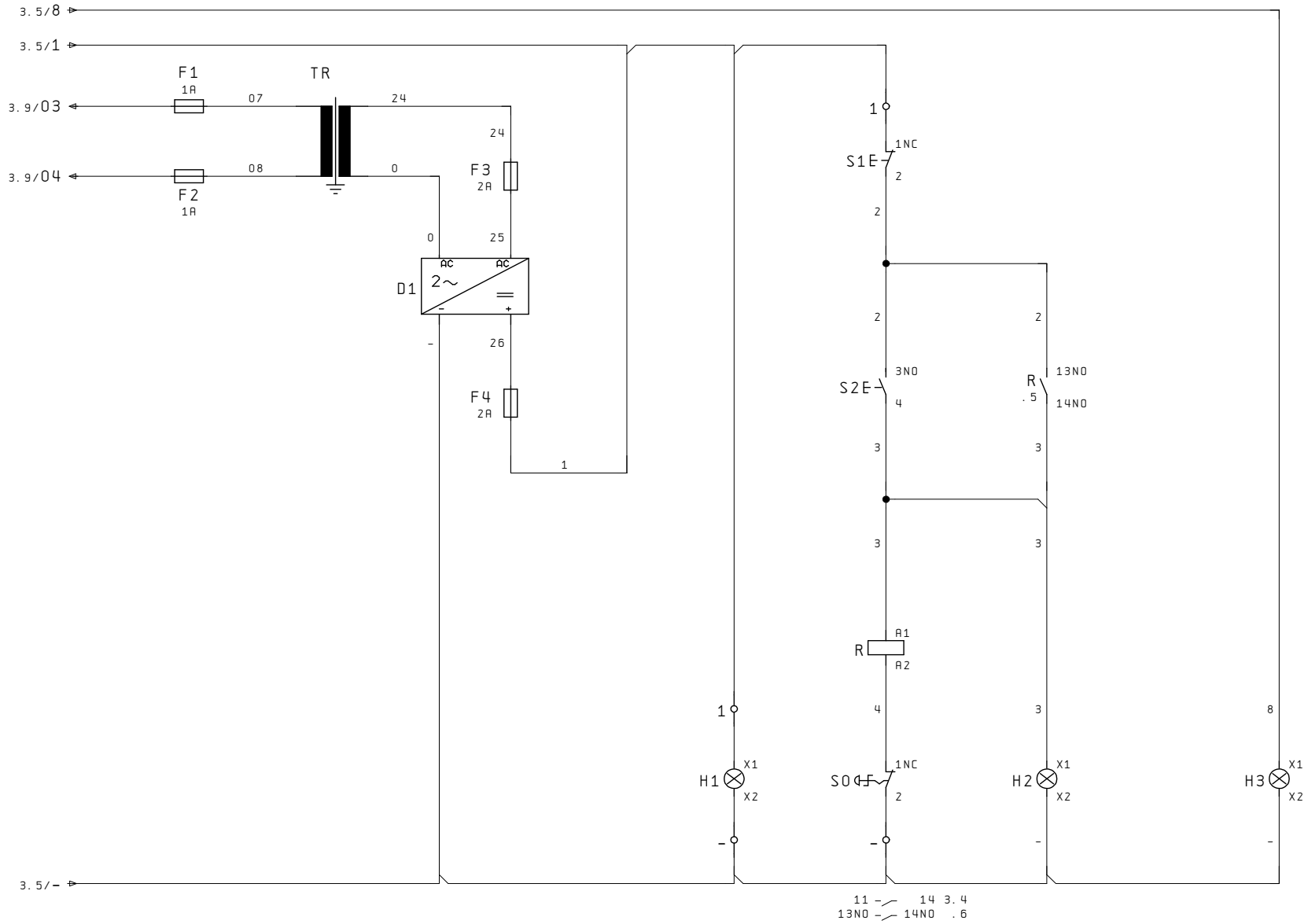

Date	26. May. 2014	PK-35 SINGLE PHASE (220V)	 Sahinler METAL MAKINA ENDUSTRI A. S.	CONTROL GROUP	Drawing number: 06072012	=	
Drawn by	ASIM CANBAZ				File number: PK3525	Project name: PK3525	P. 4
Checked by	FIRAT CILINGIR						6 P.
Norm	Original						

ELECTRICAL CABINET AND CABINET' S COVER PLAN

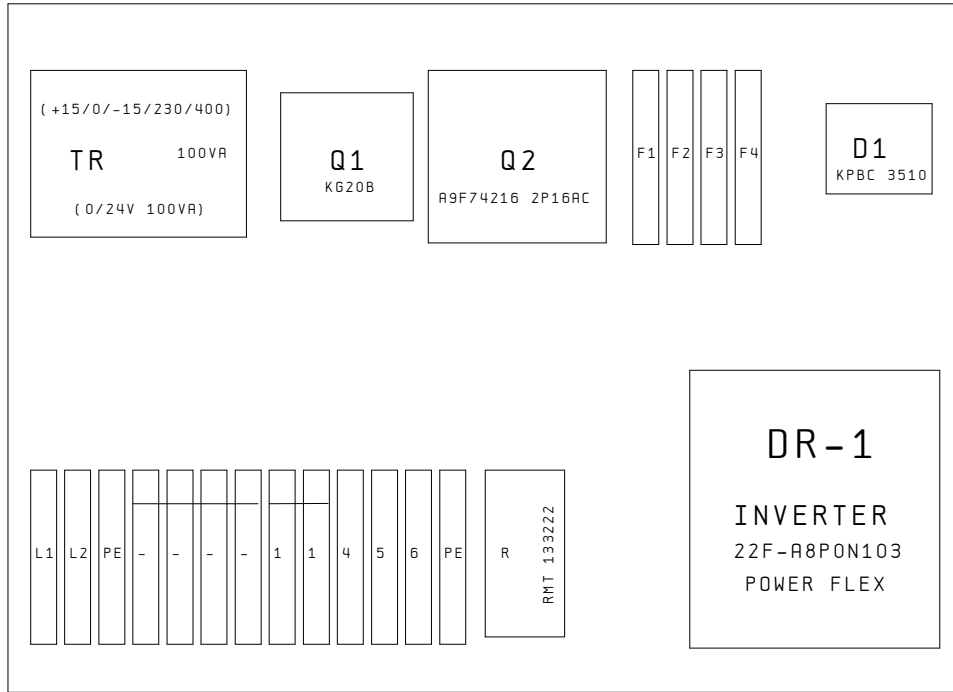

BOX

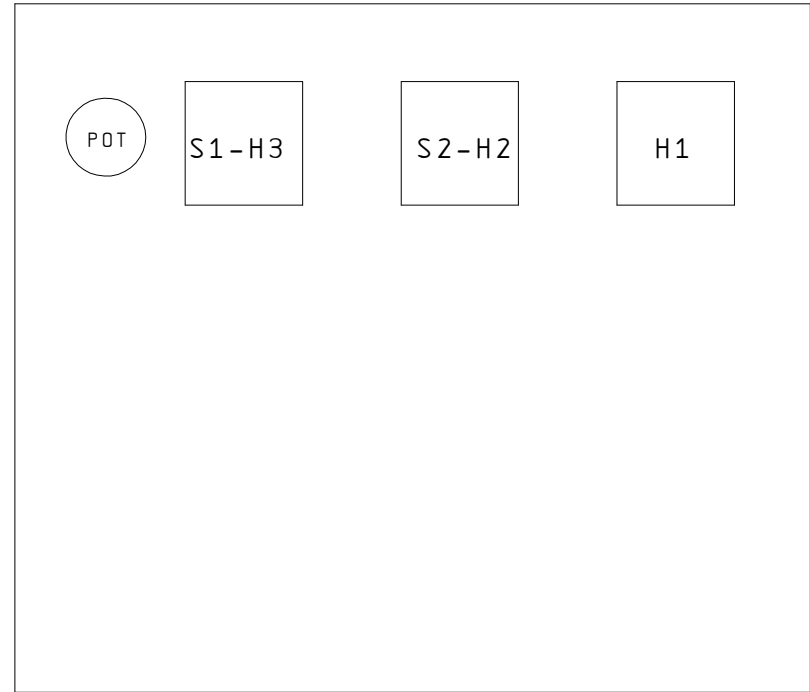

COVER

Date	26. May. 2014	PK-35 SINGLE PHASE (220V)	 Sahinler METAL MAKINA ENDUSTRI A. S.	ELECTRICAL CABINET SCHEME	Drawing number: 06072012	=	
Drawn by	ASIM CANBAZ				File number: PK3525	Project name: PK3525	P. 6
Checked by	FIRAT CILINGIR						6 P.
Norm	Original						